

LON.
D.S.B.

Trompetstykke med Tilbehør
Anvendes til alle Lokomotiver m. Tender.

4.09.

1945

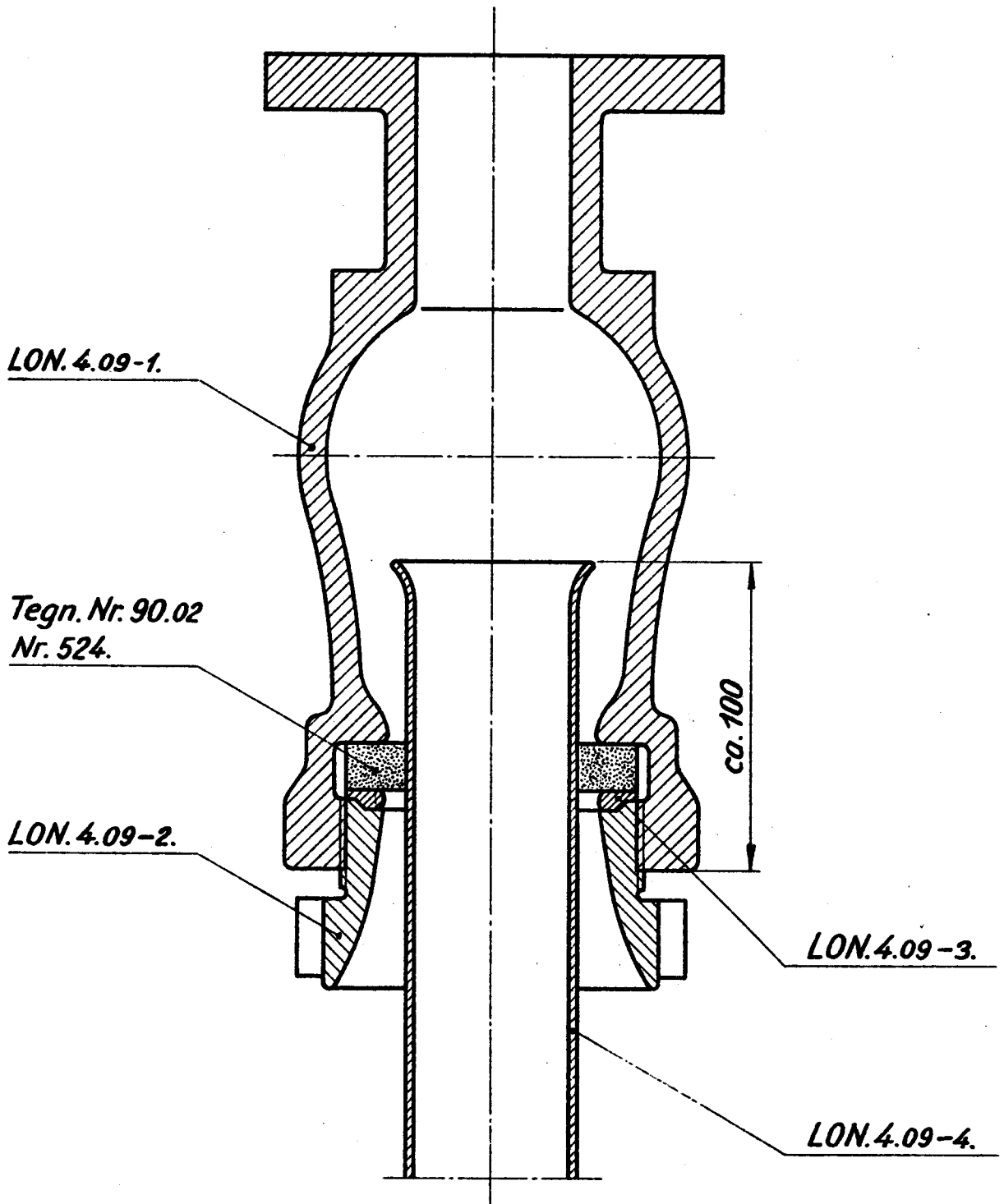

LON.
D.S.B.

Trompetstykke.
Anvendes til alle Lokomotiver m. Tender.

4.09-1.

1945

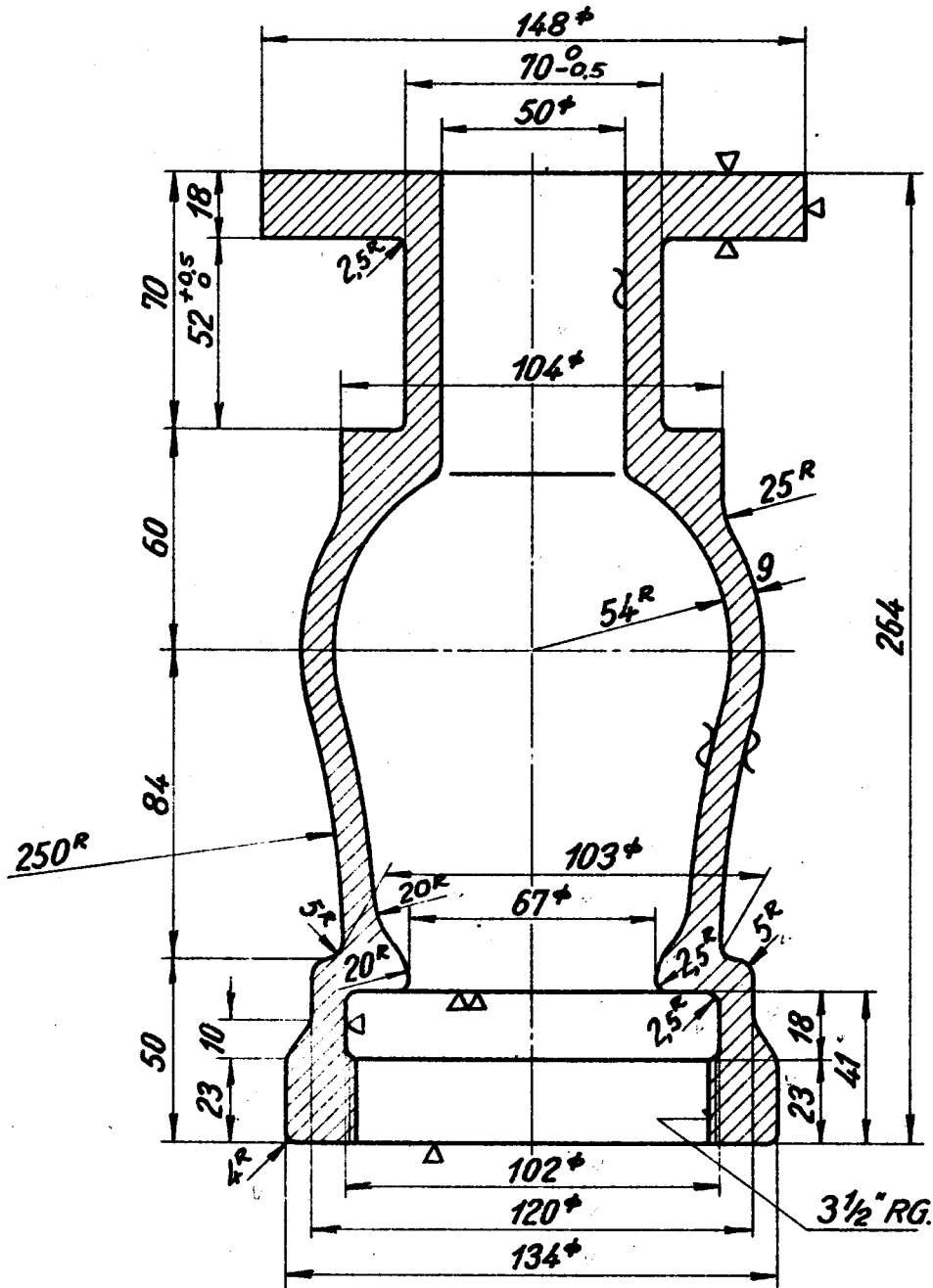

Ved Reperation af
Gevind ved Pakning
afdrejes dette, Mate-
riale paasvejses,
og nyt Gevind
skæres.

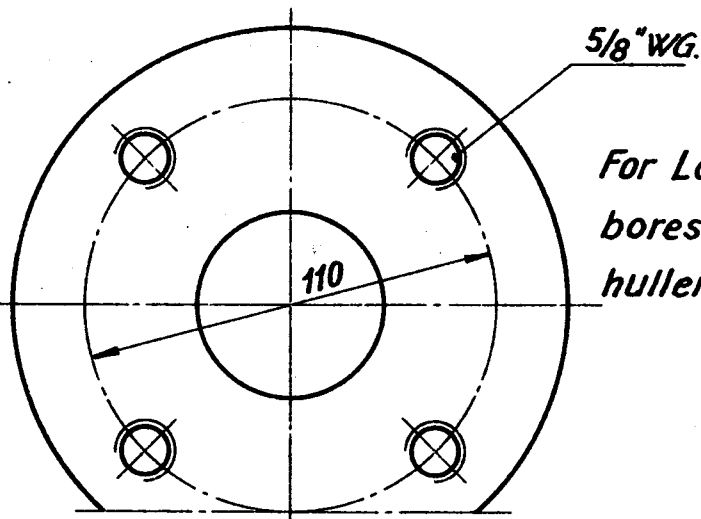

For Loko. Ltr. A
bores kun 3 Gev-
huller. i Tre deling.

Rekvissionsbetegnelse	Materiale	Model Nr.	Mindstebeholdn.
Trompetstykke, LON. 4.09-1.	Hanebronce.	1511	Kh. 12 Ar. 5.

1

LON.
D.S.B.

Pakmøtrik til Trompetstykke.
Anvendes til alle Lokomotiver m. Tender.

4.09-2.

1945

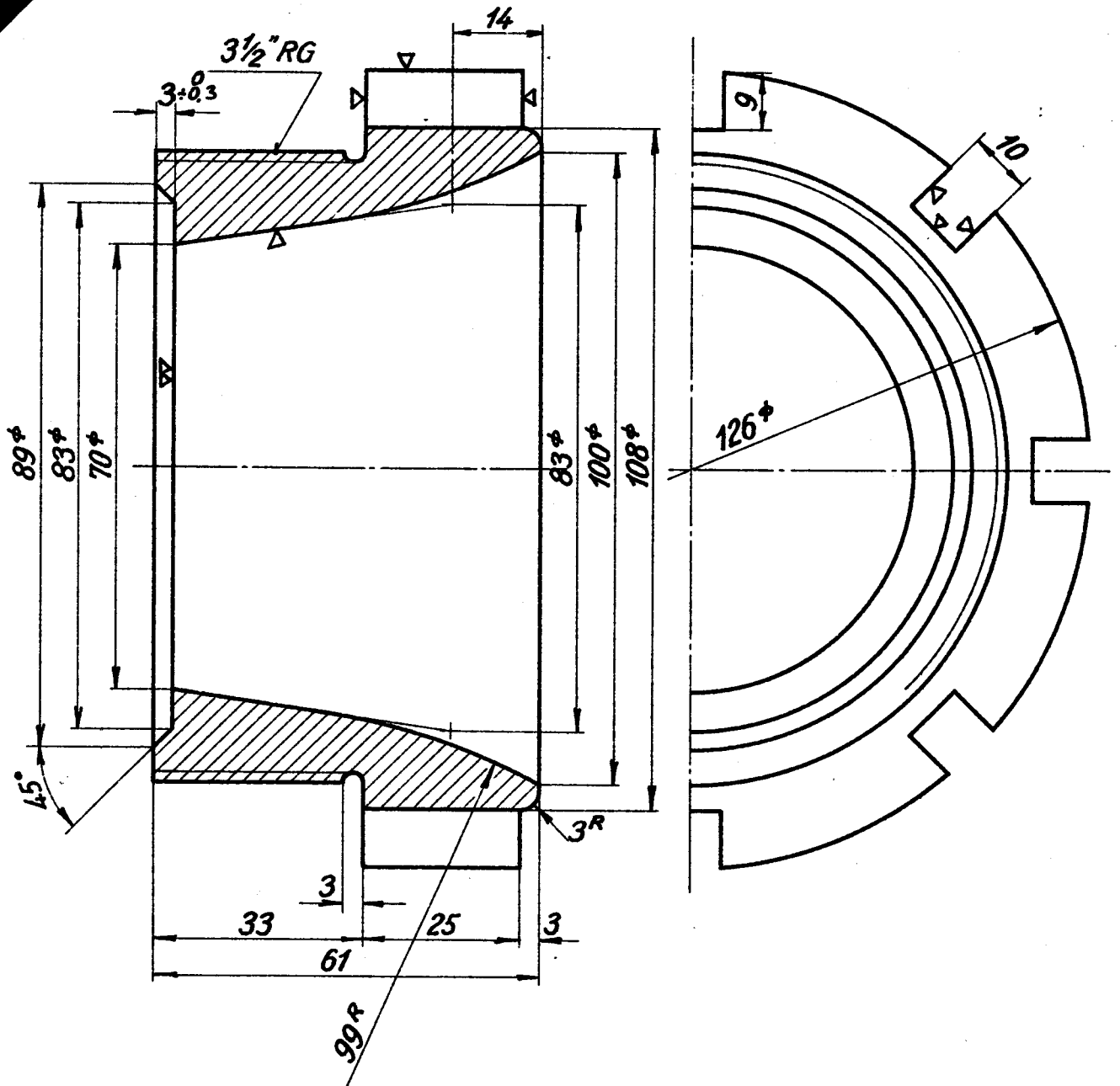

Ved Reparation af Gevindet afdrejes dette, Materiale paasvejses, og nyt Gevind skæres.

Rekvissionsbetegnelse	Materiale	Model Nr.	Mindstebeholdn.
Pakmøtrik, LON.4.09-2.	Hanebronce.	1512.	Kh. 10. Ar. 5.

2

LON.
D. S. B.

Pakring til Trompetstykke
Anvendes til alle Lokomotiver m. Tender.

4.09-3.

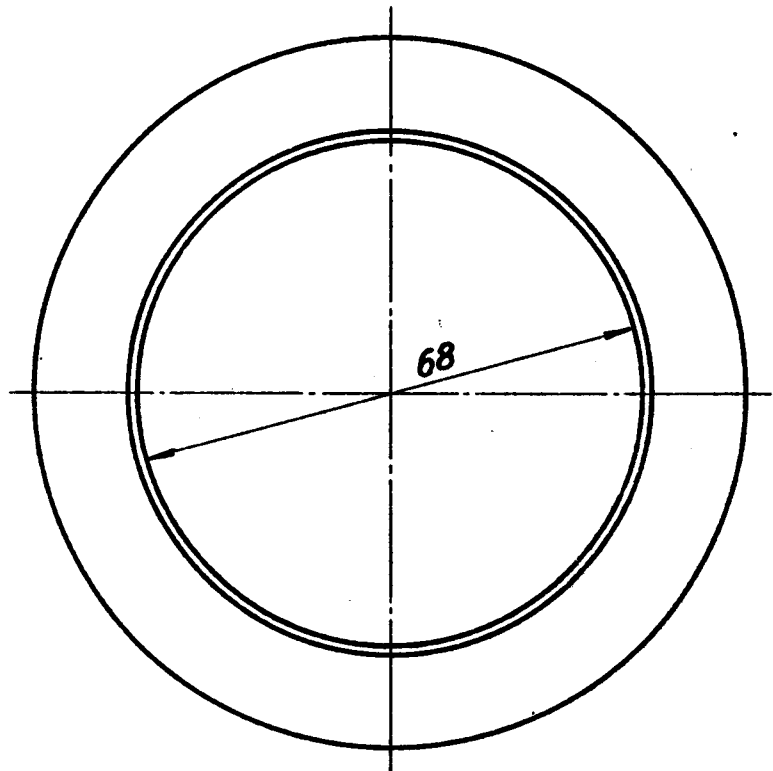
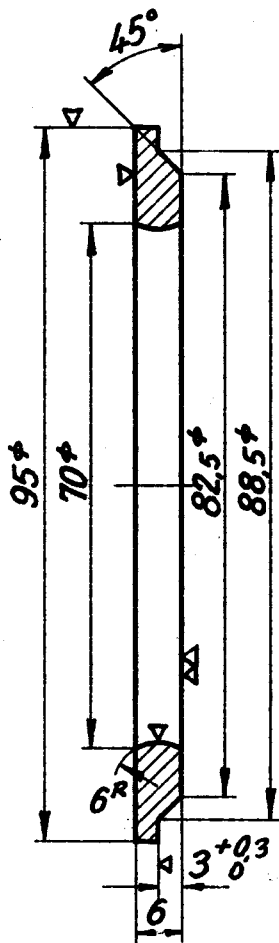

1945

Rekvissionsbetegnelse

Pakring, LON.4.09-3.

Materiale

Hanebronce

Model Nr.

2384 x.

Mindstebeholdn.

Kh. 10

Ar. 5.

3

LON.
D.S.B.

Forbindelsesrør.
Anvendes til alle Lokomotiver m. Tender.

4.09-4.

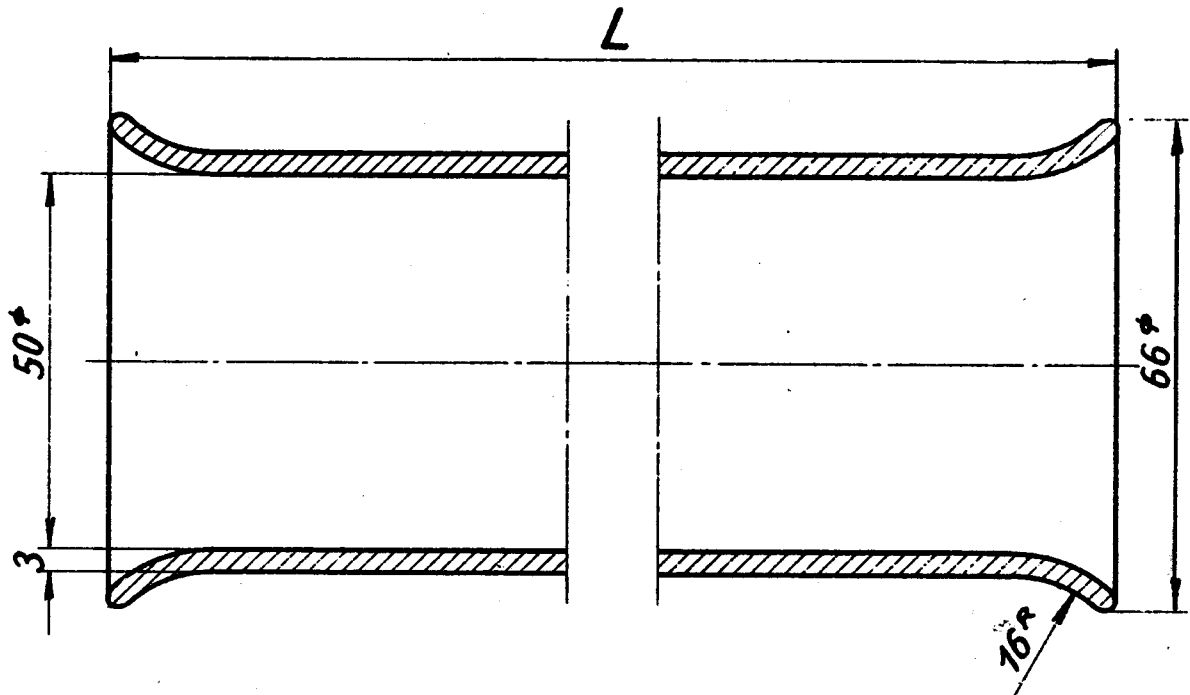

1945

(M 70 96/56)

$E_I = 980$

$E_{II} = 820$

L	Loko. Ltr.
510	A - J _{II} .
300	E _I - E _{II} .
1220	D _{II} - D _{III}
1360	C.
1410	D _{IV} - K _I - K _{II} - P _I - P _{II}
1490	G _{II} - G _{III} - H _I - H _{II} - PR _I - PR _{II} - R _I - R _{II}

Rekvissionsbetegnelse

Materiale

Model Nr.

Mindstebeholdn.

Forbindelsesrør, LON.4.09-4, L=510.

Kobber.

Kh.

Ar.

5

0
1

LON.
D.S.B.

Flange for Trompetstykke.
Anvendes til alle Lokomotiver m. Tender.

4.09-5.

1945

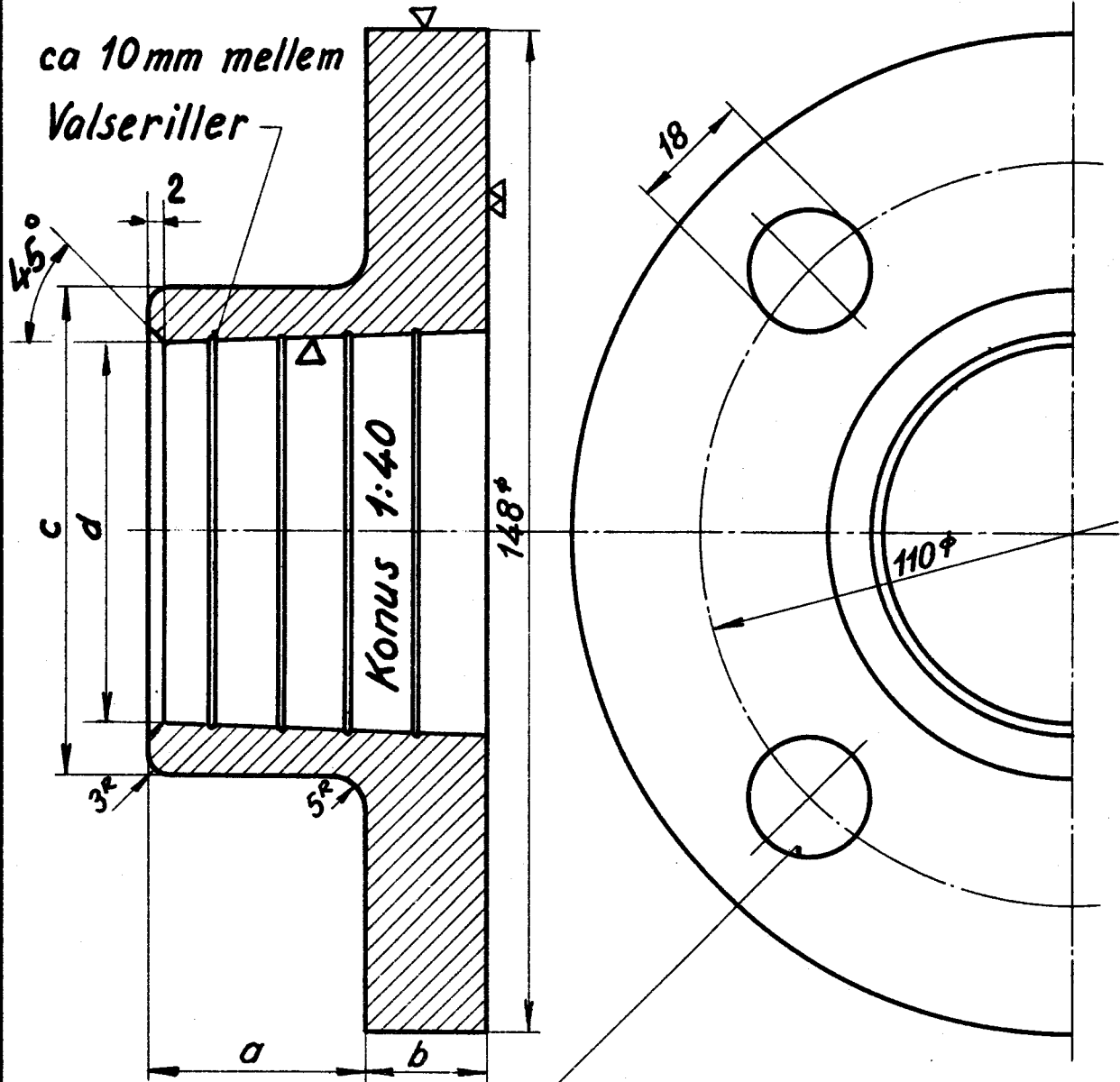

For Loko. Ltr. A bores kun 3 Huller.

a	b	c	d	Model Nr.	Loko. Ltr.
25	18	52	32	1514	A-GII-GIII-3
25	18	60	39	1516	DI-DII-DIII-KI-KII.
25	18	60	45	1516	Alle Tendere
32	18	72	56	2513	HI-HII-PI-PII-PRI-PRII-RI-RII-EI-EII.

Rekvissionsbetegnelse

Materiale

Model Nr.

Mindstebeholdn.

Flange, LON.4.09-5, d=56.

Hanebronce.

Kh.

Ar.

6